

PROCHEM®

CR2

MULTI-SURFACE EXTRACTOR



**SAFETY, OPERATION & MAINTENANCE
INSTRUCTIONS**

MODEL: RC2700 CR2 MULTI-SURFACE EXTRACTOR

- **CAUTION – READ THE INSTRUCTION MANUAL BEFORE USING THE APPLIANCE**
- **ORIGINAL INSTRUCTIONS**
- **MANUAL ALSO AVAILABLE ONLINE AT WWW.PROCHEM-UK.COM**



MACHINE DATA

MODEL NO.	
SERIAL NO.	
DATE OF PURCHASE	
DISTRIBUTOR NAME	
DISTRIBUTOR TEL NO.	
MANUFACTURER CONTACT	Prochem Europe Ltd. Oakcroft Road, Chessington, Surrey KT9 1RH, UK Telephone: + 44 (0)20 8974 1515 Fax: + 44 (0)20 8974 1511 Email: sales@prochem.co.uk Website: www.prochem-uk.com

All information and specifications in this manual are current at the date of issue. However, because of Prochem Europe's policy of continual product improvement, we reserve the right to make changes at any time without notice. Please note that this manual applies to all models and explains variations including accessories used. Therefore, you may find some explanations for variations and options not installed on your equipment.

CONTENTS

	PAGE NO.
WARRANTY	5
WARNING SECTION	6
IMPORTANT SAFETY INSTRUCTIONS	7
GENERAL DESCRIPTION OF APPLIANCE & IMPORTANT OPERATING INSTRUCTIONS	8
GENERAL OPERATING INSTRUCTIONS	9
MAINTENANCE	11
MACHINE LAYOUT	12
HARD SURFACE ACCESSORIES & TOOLS	14
ASSEMBLE ACCESSORY RACKS & OPENING MACHINE	15
CHEMICAL FEED SYSTEM & DILUTION RATIO CHART	16
OPERATING INSTRUCTIONS RESTROOM CLEANING MODE	17
OPERATING INSTRUCTIONS CARPET AND UPHOLSTERY MODE	18
STORAGE / TRANSPORT	19
GENERAL FAULT FINDING GUIDE	20
ACCESSORIES & CHEMICALS	21
PARTS DIAGRAM UPPER	22
PARTS LIST UPPER	23
PARTS DIAGRAM BASE	25
PARTS LIST BASE	26
WIRING DIAGRAM	28
CE DECLARATION OF CONFORMITY	29



This product is marked according to the **European Directive (2002/96/EC) on Waste Electrical and Electronic Equipment (WEEE)**.

The symbol on this product indicates that this product must not be disposed of with normal household waste. Please protect human health and the environment by disposing of this product responsibly in the correct manner.

For further information regarding the disposal, treatment, recycling and recovery of this product, please contact:

Prochem Europe Sales Department
Telephone: +44 (0)20 8974 1515

Prochem Europe Ltd. EEE Producer Registration Number: WEE / AJ0044SY

European Directive (2015/863/EU) Restriction of use of certain Hazardous Substances in Electrical and Electronic Equipment (RoHS2).

This equipment does not contain more than the maximum permitted levels by weight of the following substances:

Lead (Pb), Mercury (Hg), Cadmium (Cd), Hexavalent Chromium (Cr (VI)), Polybrominated Biphenyls (PBB), Polybrominated Diphenyl Ethers (PBDE)



MACHINE WARRANTY

DATE EFFECTIVE: 1/1/26

As of the above date, this warranty supersedes all previous warranties and forms part of the contract of sale. Prochem Europe Ltd. (hereafter referred to as "Prochem") guarantees this machine to be free from defects in materials and workmanship for the relevant time period as shown below, and from the actual date of purchase by the user. Proof of the purchase date from a Prochem Authorised Distributor will be required for performance of this warranty.

Rotationally moulded polyethylene tanks2 Years
All other parts except maintenance items (see below)1 Year

THIS WARRANTY EXCLUDES NORMAL MAINTENANCE ITEMS, including but not limited to HOSES, FILTERS, O-RINGS, DIAPHRAGMS, VALVES, DRIVE BELTS, GASKETS, CARBON BRUSHES and damage to motors and other components as a result of failure to replace normal maintenance items. THIS LIST IS NOT EXHAUSTIVE.

To obtain performance of this warranty, contact the Prochem Authorised Distributor who supplied the product.

The Prochem Authorised Distributor is responsible as the selling agent for the provision of initial training in the correct use and application of the machine and approved chemicals. The distributor is also responsible for service maintenance and repairs during and after the warranty period and the administration of any warranty claims in conjunction with the Prochem Service Department. Failure of any of these provisions and responsibilities may invalidate the warranty and the authorised status of the distributor.

If Prochem receives notice of any defects during the warranty period, Prochem reserves the right to either repair, or replace components that prove to be defective. Goods must be returned before the warranty is approved. Goods sent out prior to the return of faulty items will be invoiced at current prices, subject to standard payment terms (see Prochem Standard Terms and Conditions of Sale). Replacement parts supplied under warranty will be guaranteed for the remainder of the original machine warranty and **NOT** from the date of installation. Electrical spares (pumps and vacuum motors) supplied after the expiry of machine warranty may be covered by a 3 month/90-day warranty. This warranty is activated from date of purchase from Prochem, warranty may be applied after inspection by Prochem Europe Ltd. & at its sole discretion. Normal maintenance items, however, are not covered. Replacement or credit of any returned parts will be at the discretion of the Prochem Service Department. Any subsequent refusal to accept their decision will serve to invalidate this warranty with immediate effect.

PROCHEM AUTHORISED DISTRIBUTORS are responsible for machine and accessories service back up during and after the warranty period. Prochem will furnish parts if the warranty is approved, but **DISTRIBUTORS** will be responsible for fitting, service, labour and related charges including travel, if applicable, and the cost of returning the machine or parts to Prochem. If any chargeable work is undertaken by Prochem for **DISTRIBUTORS** the labour, parts (if applicable) and return carriage will be charged at **FULL LIST PRICE**. If warranty is approved due to genuine manufacturing defect, then labour charges and carriage charges may be waived at Prochem's discretion.

Prochem may send replacement parts to customers supplied by a **DISTRIBUTOR** or directly by Prochem, subject to the same conditions of replacement and payment above. The customer, however, will be responsible for fitting, labour and the carriage costs of returning repaired parts. Alternatively, Prochem will undertake warranty work at Chessington, subject to the same conditions, but the customer will be responsible for all carriage charges.

Any of the following circumstances involving the machine will serve to invalidate this warranty:-
NORMAL WEAR, ACCIDENTS, USE OF THE MACHINE FOR A PURPOSE OTHER THAN THAT FOR WHICH IT WAS INTENDED, INCORRECT MAINTENANCE, THE USE OF CHEMICALS OTHER THAN THOSE SUPPLIED OR APPROVED BY PROCHEM, INCORRECT INSUFFICIENT OR NON-USE OF DEFOAMER, EXPOSURE TO EXTREME TEMPERATURES OR CONDITIONS, INCORRECT INSTALLATION OR REPAIR & UNAUTHORISED INTERVENTION.

Liability is excluded for the following: -
All forms of damage and special damage founded in tort (apart from death and personal injury) and contract law including but not limited to consequential loss, loss of income and losses incurred in reliance of the contract; service, labour or third-party charges and the cost of returning the machine or defective parts to Prochem or Prochem's Authorised Distributor.
As against a person dealing as a consumer, this warranty creates specific rights in addition to any statutory rights, which are unaffected. As against a person dealing otherwise than as a consumer, however, this warranty excludes any implied term that the machine will correspond with a description or a product sample.
With the exception of some specific products which are labelled and intended to be used by a consumer, all equipment, machinery, accessories, products, services and advice supplied by Prochem is intended for professional and industrial use only.

Your Prochem unit is designed to give you many years of reliable service. If a problem should arise during or after the warranty period, contact the Prochem Authorised Distributor or the Prochem Service Department, for details of the services available. Only the original purchaser of the new equipment may seek performance of this warranty – these rights cannot be transferred to a third party.

Prochem Europe Ltd.
Oakcroft Road, Chessington, Surrey KT9 1RH, UK
Telephone: + 44 (0)20 8974 1515 Fax: + 44 (0)20 8974 1511

Machine Warranty Issue 11 1/1/26

WARNINGS!

- **Warning!**
Machines shall not be used by children. Children should be supervised to ensure that they do not play with the appliance. This machine can be used by people with reduced physical, sensory or mental capabilities or lack of experience and knowledge if they have been given supervision or instruction concerning the use of the machine in a safe way and understand the hazards involved.
- **Caution:** this machine is for indoor use only.
- **Caution:** this machine shall be stored indoors only.
- **Warning!**
This machine must be disconnected from the mains during cleaning or maintenance, when replacing any parts or converting the machine to another function.
- **Caution:** under no circumstances should the machine be carried by or bumped up a flight of stairs using the handle, always empty the solution and waste tanks before storage or transporting the machine.

IMPORTANT SAFETY INSTRUCTIONS

**PLEASE READ THE FOLLOWING IMPORTANT SAFETY INSTRUCTIONS (!!)
BEFORE ATTEMPTING TO USE THIS MACHINE. FAILURE TO OBSERVE THE
INSTRUCTIONS MAY RESULT IN PERSONAL INJURY.**

!! CAUTION

Read the instruction manual before using the appliance.

!! SOUND PRESSURE LEVEL

The sound pressure of this machine, when in use, does not exceed 85 dB (A).

!! APPLIANCE SUITABILITY

This appliance is suitable for commercial use, for example, in hotels, schools, hospitals, factories, shops, offices and rental businesses.

!! FOR MAINS POWERED APPLIANCES during cleaning and maintenance – the plug is to be removed from the outlet socket.

!! TRAINING

You must be trained in the operation of this machine before use. Please read this manual carefully and obtain operating instruction from your Prochem Distributor or authorised representative in the correct use of this equipment and suitable chemicals before attempting to clean.

!! REPAIRS

Should any repairs, including supply cord replacement be required, we recommend that the appliance be returned to an authorised dealer.

!! ELECTRICAL CABLE INSPECTION & REPLACEMENT

This machine must be earthed while in use to protect the operator from electric shock. It is equipped with a sealed and approved EC three conductor cable and three-prong 13A plug. If the supply cord is damaged it must be replaced by a special cord or assembly available from the manufacturer or its service agent. During operation a hazard may occur when running the machine over the power supply cord. The power supply cord should be regularly inspected for signs of damage. If the power supply cord is damaged, it must be replaced.

!! RCD CIRCUIT BREAKER

In common with other household and commercial electrical equipment, an 'RCD' circuit breaker plug device is strongly recommended for this type of equipment.

!! EXTENSION CABLES

Avoid using extension cables with this machine. If an extension cable is used it should be of a suitable rating and no longer than 30 metres. Use only three wire CE approved extension cable with CE approved three-prong earthed plugs and three pole receptacles that accept the machine 13 amp plug.

!! DO NOT use a multiple adaptor socket to connect the machine and heating units or other devices to a single extension cable.

!! DO NOT stand the machine in water to operate such as during flood extraction.

SERIOUS INJURY OR DEATH MAY RESULT IF MACHINE IS IMMERSSED IN WATER!

!! DO NOT pull the machine by the power cable or hoses.

!! DO NOT use this machine with or near flammable vapours. These machines can ignite flammable vapours such as fuels, solvents or thinners.

!! DO NOT operate the machine unless it is completely assembled.

!! DO NOT attempt repairs or maintenance unless you are suitably qualified or experienced. Repairs and maintenance should only be performed by qualified personnel and the machine should be tested for electrical safety before re-use.

!! SPRAY LIQUID ejection could be hazardous as a result of its temperature, pressure or chemical content.

!! IF FOAM or liquid comes from the exhaust switch off immediately.

!! ALWAYS disconnect machine from mains supply when left unattended, when emptying the waste container or cleaning the appliance.

!! WHEN CLEANING THE WASTE TANK use a broad spectrum disinfectant cleaning agent to prevent contamination from any infectious material.

GENERAL DESCRIPTION OF APPLIANCE

The CR2 machine is designed for “touchless” cleaning. It incorporates a high pressure 500psi pump, a single vacuum unit for wet extraction and a chemical metering system.

The machine has a separate clean water tank and a waste water tank for the collection of dirty water.

The machine can also be fitted with various accessories to convert the machine to an upholstery and carpet cleaning unit.

IMPORTANT OPERATING INSTRUCTIONS

PLEASE READ THE FOLLOWING IMPORTANT OPERATING INSTRUCTIONS (!) BEFORE ATTEMPTING TO USE THIS MACHINE. FAILURE TO OBSERVE THE INSTRUCTIONS MAY RESULT IN DAMAGE TO THE EQUIPMENT.

! DO NOT expose the machine to rain or freezing temperatures. Drain solution system and store indoors when not in use.

! DO NOT operate the machine without solution and waste tank filters.

! DO NOT use boiling water or temperature in excess of 76°C.

! DO NOT use chemicals in the machine other than those manufactured or recommended by Prochem Europe.

! DO NOT use the machine for dry vacuuming. The vacuum must only be used for wet extraction in conjunction with the spray system.

! DO NOT run the solution pump and/or heating unit dry. Always switch off and disconnect the machine and/or heating unit electrical supply when re-filling with solution.

! ALWAYS use a clean bucket to fill the solution tank.

! AFTER USE flush solution system and rinse the waste tank with clean water and remove loose fibres from the vacuum filter.

! ALWAYS observe directions and safety precautions on chemical products.

! ALWAYS pre-test carpet or fabric for colour fastness and suitability with ready-to-use cleaning solution before proceeding.

! ALWAYS use defoamer in the waste tank to control foaming from previous shampoo residues in the carpet.

! IF POWDERED CHEMICALS are used, always premix in a separate bucket before adding to solution tank. If not properly dissolved, powdered cleaning solution may result in damage to the solution pump.

! USE ONLY genuine replacement parts for this machine, supplied by an authorised Prochem Distributor.

! DO NOT use this machine for any purpose other than for its intended design function. Any deviation from its proper use or purpose and any consequential **damage** that may occur is the sole responsibility of the user.

! ALWAYS discharge soiled solution to a sewage drain linked to a sewage treatment facility.

! DO NOT discharge soiled solution into roadside storm drains.

! DO NOT use the drain valve to lift the machine which may result in damage to the drain valve or leakage from the drain valve mounting.

GENERAL OPERATING INSTRUCTIONS

UNPACKING YOUR NEW CR2:

When your package is delivered, check the packaging carefully for signs of rough handling. If your CR2 is damaged, notify the carrier immediately and request an inspection. Be sure to keep the box, packing inserts, packing lists and carrier's receipt until the inspector has verified your claim.

PROCHEM'S liability ceases when the carrier picks up the shipment. However, our customer service staff will be happy to furnish any information needed in connection with the claim and will attempt to expedite a resolution.

PLEASE READ BEFORE OPERATING YOUR NEW CR2:

Read the manual carefully and completely before attempting to operate the unit. This manual has important information for the use and safe operation of the machine. Keep this manual handy at all times.

This equipment has been engineered and manufactured to provide excellent performance and service.

To ensure that your equipment will continue to perform as intended:

Maintain equipment regularly- following the suggested maintenance schedule provided.

Use only original PROCHEM parts when servicing.

Operate equipment with care.

If additional information is needed, please contact:

PROCHEM 0208 974 1515

All information and specifications printed in the manual are current at the time of printing; however, because of PROCHEM'S policy of continual product development, we reserve the right to make changes at any time without notice.

FAILURE TO COMPLY WITH THE FOLLOWING WARNINGS AND INSTRUCTIONS WILL VOID THE WARRANTY.

WARNING!

The machine was designed for use on hard surfaces and carpet and upholstery applications (using optional accessories) as per instructions and recommendations written in this manual. Any deviation from its proper use or purpose and the consequential damage that may occur is the sole responsibility of the end user.

Disconnect the power cord from the outlet before servicing. Do not leave machine connected to an electrical outlet when unattended.

Do not immerse or use this machine in standing water. Such use may cause electric shock.

When using an extension cord, use only a 3-prong conductor grounding cord 12-gauge wire or heavier.

To avoid electric shock, do not expose the unit to rain or snow. Store it indoors in a heated location only.

Do not use the machine for dry vacuuming.

Use defoamer at all times to prevent damage to the vacuum motor.

Do not use water in excess of 76°C in the solution tank.

To prevent seal damage and chemical build-up to the pump system, run clean water through the solution lines after each day's use.

Use only cleaning chemical products and defoamer recommended by Prochem Europe. Do not use dyes, bleaches, ammonia, or other additives.

The use of powdered cleaning solution, if not diluted properly, may result in damage to the pump. Powdered chemical is not recommended. If powdered chemicals are used, premix in a separate container before placing in the solution tank.

Always read and understand the chemical SDS (Safety Data Sheet) before use.

This equipment is not designed to handle or use combustible/volatile substances such as gasoline or kerosene, in, on, or near the machine. The use of such materials will cause extreme hazardous condition.

Do not expose machine to freezing temperatures

All repairs must be carried out by an authorized PROCHEM repair station.

Do not use replacement parts other than original PROCHEM parts.

Do not allow your spray stream to remain in one fixed location as surface damage may occur.

Check that all spray nozzles are securely fastened. Loose nozzles could be ejected from equipment at high speeds.

Prevent burns by wearing gloves or using a barrier to remove hot quick disconnects.

CR2 is **not** a toy. Keep away from children.

Do not pull by the power or use power cord as a handle. Always unplug by grabbing the plug and pulling, do not unplug by pulling the power cord. Inspect cord for damage.

Do not use damaged cords. Connect only to properly grounded outlets. Keep hair, fingers, loose clothing, and body parts away from moving parts and openings.

Turn off all controls before disconnecting machine

Use caution with ejected liquid or chemicals. High pressures and temperatures could be hazardous to nearby people or surroundings

BEFORE OPERATING THE MACHINE

Read the manual carefully and completely before attempting to operate the unit. This manual has important information for the use and safe operation of the machine and should be kept available at all times. This machine will ensure years of satisfactory service if operated and maintained according to recommendations in this manual. If additional help or information is needed, please contact your distributor or Prochem.

Prochem machines have been designed with the operator in mind. Provided you read the instructions relating to the care of your machine and follow them carefully and take advantage of the helpful hints and advice that we have passed on, you will achieve excellent cleaning results and very quickly pay for your investment. A detailed operational guide is given in the following sections, however, the following important points must be emphasised.

FAILURE TO OBSERVE THESE INSTRUCTIONS MAY SERIOUSLY AFFECT THE PERFORMANCE OF THE MACHINE AND INVALIDATE THE WARRANTY

- Connection instructions - The 220 - 240V AC models have been fitted with the appropriate EC type sealed power cable and 3 prong 13 amp plug for the UK market. Ensure the machine is connected to a 13 amp socket outlet having the same configuration as the plug. No adapter should be used with this machine. Any modification to the plug type may be dangerous and will void the warranty.
- This equipment is intended for commercial use only.
- The machine is designed for use on hard surfaces but can be adapted with the use of certain accessories to be used for carpet and upholstery applications as per instructions and recommendations written in this manual. Any deviation from its proper use or purpose and the consequential damage that may occur is the sole responsibility of the end user.
- Disconnect the power cord from outlet before servicing. Do not leave machine connected to an electrical outlet when unattended.
- Do not immerse or use this machine in standing water. Such use may cause electric shock.
- This equipment is not designed to handle or use combustible/volatile substances such as gasoline or kerosene, in, on, or near the machine. The use of such materials will cause an extreme hazardous condition.
- Use defoamer at all times to prevent damage to the vacuum motor(s).
- Do not use water in excess of 170°F (76°C).
- To prevent seal damage and chemical build-up to the pump system, run clean water through the solution lines after each days use.
- All repairs must be carried out by an authorised Prochem distributor.
- Repairs should only be carried out by a qualified person.
- Do not use replacement parts other than genuine manufacturer's parts as specified in the parts list.

- Do not use chemicals in the machine other than those supplied or approved by Prochem Europe limited.
- Do not use the machine as a 'dry' vacuum. Always pre-vacuum carpets thoroughly with a separate 'dry' vacuum cleaner.
- Keep the solution tank and filter clean. Always use a clean bucket to fill the solution tank.
- Clean the waste tank, vacuum filter and fall-out tube daily. Do not allow the vacuum shut-off filter to clog and do not restrict the free movement of the ball float (where fitted). Empty recovery tank regularly during use, do not wait for it to fill up and cut the vacuum motor out.
- Clean the drain hose regularly and replace end cap.
- After use, flush through the pump, solution lines and waste tank with at least two gallons of hot water.
- Do not allow the machine, hoses or tools to freeze. Freezing may seriously damage the pump and fittings. Always drain solution and store indoors when not in use. When in transit during freezing weather, insulate and cover machine, wand and hoses. To prevent hose cuffs splitting in cold conditions, immerse them in warm water before use.

MAINTENANCE:

This CR2 has been engineered and built to require minimum maintenance. But like any machine, it does require some care to keep it in optimum working condition. Careful attention to these maintenance instructions will give you maximum operating performance and life expectancy of the machine.

CAUTION: Disconnect the power cord from the outlet before doing any clean up or maintenance on the machine

1. Keep the machine clean. Do not allow dust to accumulate on external surfaces or near any moving parts.
2. After every job, wipe down the surface of the machine with a clean damp cloth.
3. Inspect cord for damage. Do not use machine with a damaged cord.

PERIODIC MAINTENANCE

Use only chemicals recommended by Prochem Europe or your distributor.

Adhere to the appropriate mix ratios for all chemicals

Do not add chemical to the solution tank- use the chemical feed system or pre-spray

For optimal performance, it is suggested that the operator flush the system after every job or at the end of the day.

Pump seals and valves may need to be replaced at the 1000 hour mark if a loss in pressure is noted

The pressure regulator may require servicing should a pressure drop be noted

DAILY:

Flush chemical lines with water by placing clean water in the solution tank and using the pump to spray.

Check and clean vacuum filter

WEEKLY:

Check and clean solution filter

Check for obstructions in vacuum pathways

QUARTERLY:

Check pump, plumbing and fittings for leaks

Check power cords and hoses for tears

CORD STORAGE:

While not in use, storage can be accomplished by winding cord around accessory racks. Cord should be completely unwound during operation.

CORD SAFETY

Do not leave appliance when plugged in. Unplug from outlet when not in use and before servicing

Do not use with damaged cord or plug. If appliance is not working as it should, has been dropped, damaged, left outdoors, or dropped into water, return to service centre for inspection and repair.

Do not pull or carry by cord, use cord as handle, close a door on cord, or pull cord around sharp edges or corners. Do not run machine over cord. Keep cord away from heated surfaces.

Do not unplug by pulling cord. To unplug, grasp the plug, not the cord.

Do not handle plug or appliance with wet hands.

This equipment should be stored indoors and not exposed to rain.

MACHINE LAYOUT

1. Handle- Used to manoeuvre and position the CR2
2. Recovery tank lid- Allows access to recovery tank and creates a seal to ensure suction
3. Solution tank lid- Allows access to the solution tank and prevents external contamination of solution tank
4. Accessory racks for hoses, cords, tools etc.- Two large racks on one side and three small racks on each side of the machine.
5. Wand storage bracket and Velcro strap. Allows the operator to secure a wand attachment to the machine for ease of transport
6. Non-marking front 4" locking casters and rear 10" wheels
7. Recovery/vacuum hose inlet barb- connect your recovery vacuum hose to this barb
8. Feed hose line for chemical with threaded bottle cap- secures the feed hose line to the chemical bottle
9. Bottle holder for chemical feed system- Holds up to a one gallon chemical bottle
10. Not Used on UK models

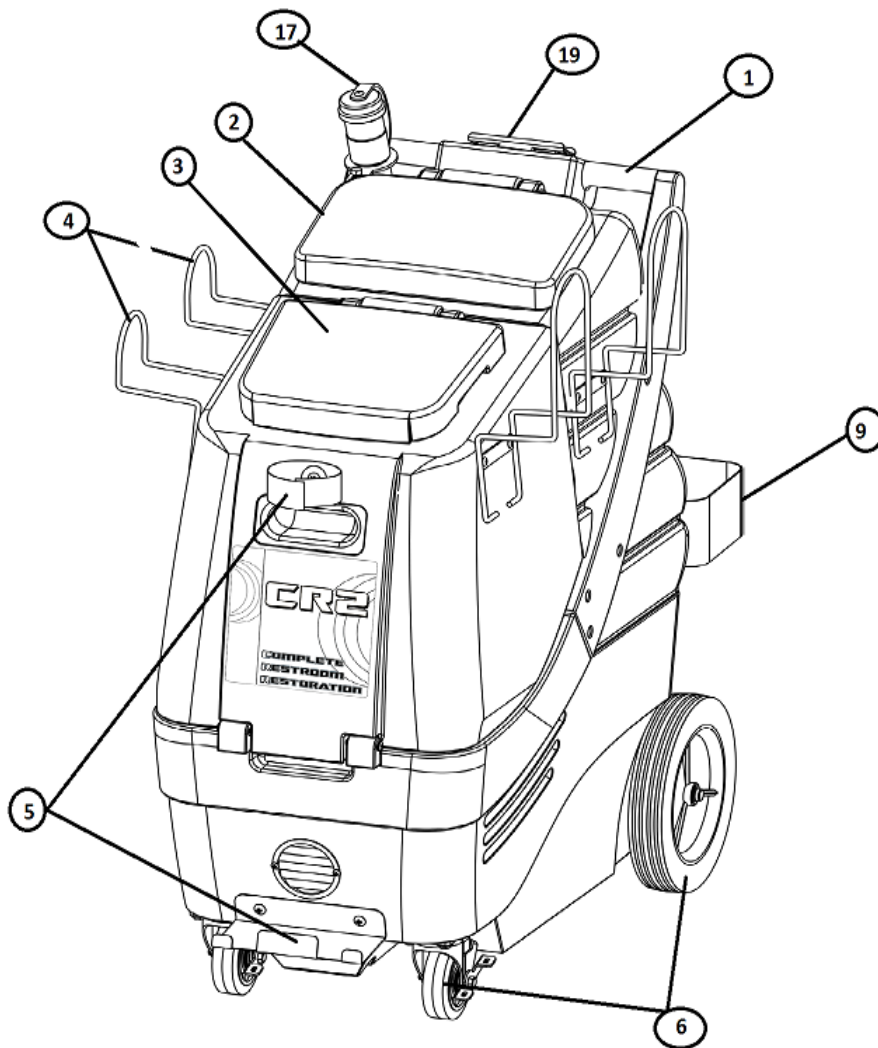

MACHINE LAYOUT

11. Chemical dispensing valve- Select between "SOAP" and "RINSE" by turning to left or right as marked
12. Power cord
13. Exhaust port hose barb- Used to connect to hose with blower attachment.
14. Pressure regulator- Decrease pressure by turning counter-clockwise or increase pressure by turning clockwise
15. Priming/pressure relief valve- Prime system in the event of air lock. Relieves pressure in the event of pressure lock
16. Solution line Q.D.- Pressurized connection for solution line
17. Recovery tank dump hose
18. Heater mounting brackets- for accessory heater
19. Switch box- one switch marked "PUMP" and one switch marked "VACUUM". Switches light up when powered on.

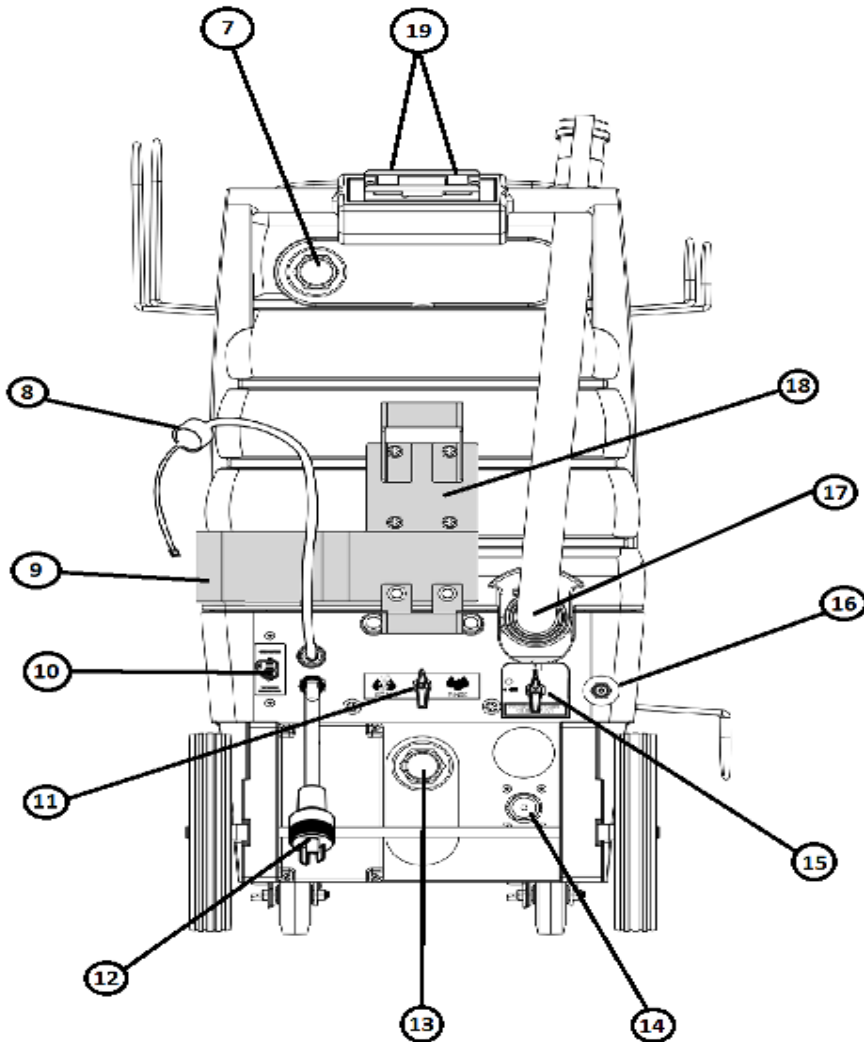

HARD SURFACE ACCESSORIES/TOOLS



2 piece wand and reversible brush/squeegee head assembly. For scrubbing on one side and picking up water on the other. Connects to hose #4 on this page.



“Gulper” tool Used to extract large volumes of water. Connects to hose #4 on this page.



50FT high pressure solution line. Connects to quick disconnect on CR2



45 FT Vacuum Hose. Connects to vacuum hose inlet barb on CR2



45ft Blow hose. Connects to Exhaust port on CR2



High Pressure gun. Connects to hose #3 on this page.



Hand Squeegee
Used to remove excess liquid from smooth vertical surfaces.



Faucet Adapter. Presses on to most standard faucets to easily fill the CR2 without using buckets.
*NOT SHOWN- ACCESSORY MESH BAG

Assembling the accessory racks:

The CR2 is shipped with the accessory racks and hardware in the solution tank. When you receive your CR2, it is necessary to secure the racks to the body. The only tool required to complete the assembly is a Phillips head screwdriver.

The CR2 comes equipped with threaded inserts pre-installed in the body. The two larger racks are installed toward the front of the machine- one per side and the two smaller racks are installed toward the rear, also one per side.

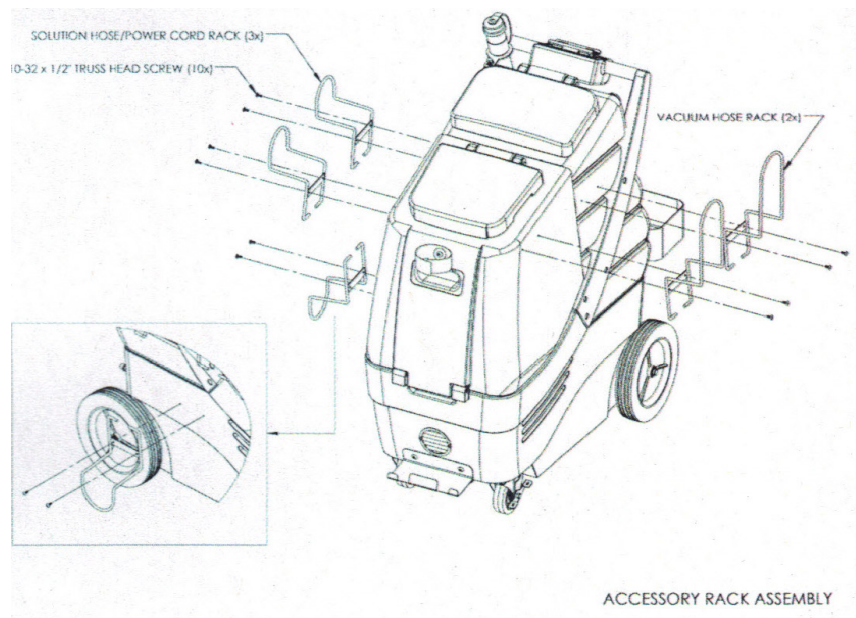

Opening the machine:

This unit can be opened by simply removing two bolts located on the back of the machine. The unit will open forward by lifting up on the handle. If you need to open the unit further, you may release the vacuum hose going from the base of the vacuum plate to the bottom of the recovery tank by loosening the hose clamp at the base of the recovery tank.

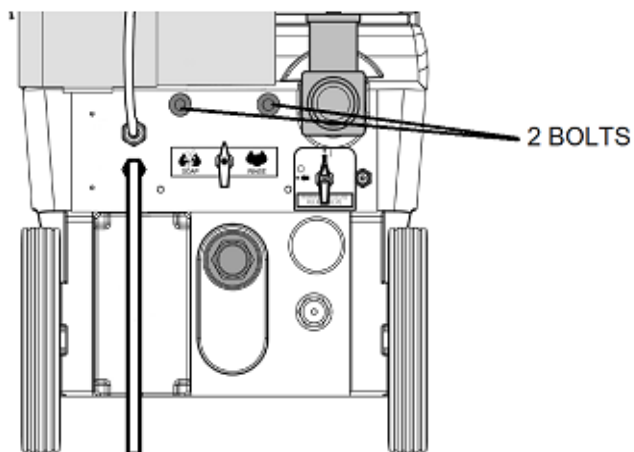

Installing metering tips for the Chemical feed system:

Remove the semi-clear hose from the bottle cap (#8 on page 7). Metering tips have a threaded pattern that is matched to the bottle cap.

Select the appropriate metering tip, using the chart below, and thread it clockwise into the threaded tube on the bottle cap. Turn counter-clockwise to remove.

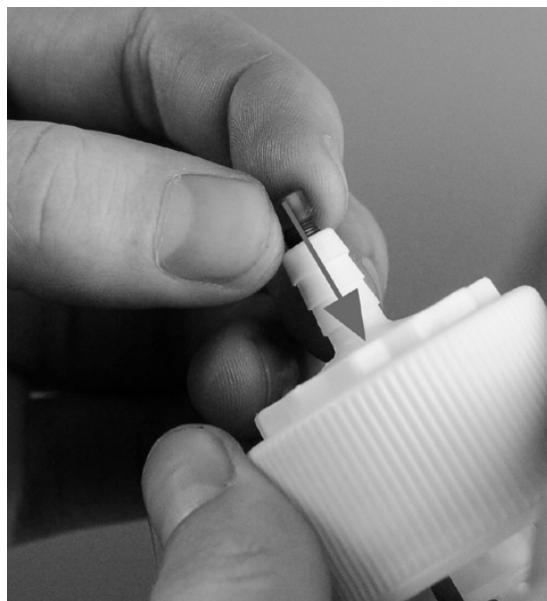

Metering tip colour guide:

TIP COLOR	RATIO	OZ/GAL	ML/L
TAN	128:1	1	7.8
PINK	64:1	2	15.6
LIGHT BLUE	43:1	3	23.4
RED	32:1	4	31.2
GREEN	26:1	5	39.1
YELLOW	13:1	10	78.2
PURPLE	6.5:1	20	156.4
NO TIP	5:1	25	203

OPERATING INSTRUCTIONS RESTROOM CLEANING MODE

Hard surface Cleaning with Chemical feed system:

The chemical feed system is designed to deliver accurate chemical dilution for touchless surface cleaning.

Fill the solution tank of your CR2 with sufficient water for the task at hand.

Connect solution hose and accessory pressure gun.

Select the appropriate tip and install on the cap of the chemical feed.

Place a bottle into bottle holder. Take the feed tube attached to the cap and place it inside the bottle.

Take the cap of the feed tube and attach it onto the bottle of chemical to secure it in place.

Turn the chemical dispensing valve to the left toward the word "SOAP".

Chemical will draw accurately only in the "LOW" pressure setting of your pressure gun. To activate the "LOW" pressure, pop the collar of the gun out.

In "LOW" pressure, apply chemical to the walls and fixtures starting from the lowest point to the highest.

Spray the floor as you make your way out of the room.

Allow the chemical to dwell according to the chemical manufacturers recommendations.

You may use the brush on your squeegee/brush wand to agitate particularly soiled areas.

When you are ready to rinse away the chemical, simply turn the chemical dispensing valve to the word "RINSE".

Set your pressure gun to the desired pressure and angle of spray by adjusting the collar. Rinse surfaces starting from the top down.

See "Recovering liquid" for final steps.

Recovering liquid from hard surfaces:

The CR2 is equipped with two dedicated tools for liquid recovery: The squeegee/brush wand and the Gulper tool.

Connect recovery vacuum hose to the waste tank inlet barb.

Place the vacuum switch into the "ON" position.

Using either the squeegee/brush wand or the Gulper tool, to extract the liquid from the surface.

Monitor the levels in the recovery tank and empty as necessary. Use defoamer to ensure your vacuum motor does not take in foam/fluid.

Using the blower feature:

To use this feature, connect the Blower hose to the vacuum exhaust outlet barb and turn on the vacuum motor.

Convenient for:

- . Blowing fluid off countertops and walls onto the floor
- . Drying taps and other fixtures
- . Blowing off dust

NOTE: Do not leave the blower hose on during normal extraction as it will restrict suction

OPERATING INSTRUCTIONS CARPET AND UPHOLSTERY MODE

PUTTING INTO SERVICE

Ensure all switches are in the off position.

Pour clean water into the solution tank using a bucket with pouring lip. Do not overfill the solution tank.

Connect the vacuum hose from the cleaning tool to the vacuum hose inlet on the recovery tank.

Connect the solution hose quick connector from the cleaning tool to the quick connector on the back of the machine. (Pull back outer sleeve on female connector and push fit onto male connector so that the outer sleeve snaps shut).

Make sure the drain hose cap is pushed fully home.

Add defoamer solution (as per label instructions) to the waste tank.

Place selected chemical bottle into bottle holder. Take the feed tube attached to the cap and place it inside the bottle.

Take the cap of the feed tube and attach it onto the bottle of chemical to secure it in place.

Turn the chemical dispensing valve to the left toward the word "SOAP".

Ensure correct metering tip is fitted to enable the correct dilution ratio. Please check chemical bottle label for correct dilution ratio and cross reference with chemical dosage tip selection chart (Page 17)

When moving the machine from place to place use the handle and wheel using the 2 rear wheels and front castor wheels.

Only place the carpet wand or hand tool onto the area to be cleaned when in use.

The machine must be used in an upright condition on a flat and level surface.

WARNING: FOR ALL UNITS FITTED WITH A HEATER UNIT DO NOT TURN ON HEATER UNTIL PUMP IS PRIMED AND WATER IS RUNNING THROUGH CARPET WAND.

OPERATING INSTRUCTIONS - CARPET WAND

Important: Use only Prochem wands and hand tools with the CR2 machine. They are designed to deliver and maintain the correct amount of solution and pressure when attached to the CR2 pump system. Use of other manufacturer's wands may cause over-wetting of carpet, damage to the pump system and lack of pressure.

Plug the machine into a suitable electrical outlet.

Turn on the vacuum and pump switches. Slowly pull the wand head towards you with the solution valve trigger engaged. Then make a pass forward and backward with the vacuum only (no spray) over the cleaned area to remove as much soil and solution as possible. Do not over-wet carpet! Make overlapping passes to prevent streaking.

On heavily soiled carpets, we strongly recommend using a pre-spray solution. If the carpet is heavily soiled, squeeze solution valve lever on the forward pass as well as backwards, allowing cleaning solution a few seconds longer to work prior to vacuuming.

When you run out of solution, turn off the pump. Detach waste water drain hose, remove cap and empty into a bucket. Dirty solution will pour out until the tank is empty. Replace drain hose cap and reattach hose to stowage point. Use a clean bucket when you refill the solution tank.

When the job is completed, turn the switches off and disconnect the vacuum and solution hoses from the carpet tool and the machine. Drain the recovery tank through the drain hose as above.

IMPORTANT INFORMATION FOR 500 PSI MOTOR PUMP FITTED TO CR2 MACHINES.

In order to gain maximum life for this pump, users are advised to **discharge the pressure in the solution system before starting or re-starting (after switching off) the pump.** This can be done by opening the wand or hand tool trigger valve and discharging pressurised solution into a bucket.

CLEANING UPHOLSTERY

CAUTION – WE STRONGLY RECOMMEND ATTENDING AN UPHOLSTERY CLEANING COURSE BEFORE ATTEMPTING TO CLEAN FABRIC UPHOLSTERY.

General instructions

Cleaning upholstery with success requires a good knowledge of the type of fabric to be worked on. Look for the cleaning instruction label sewn on the underside of the furniture for the recommended method of cleaning the fabric. If it calls for dry cleaning, do not attempt to clean with the wet extraction method. Otherwise, damage to the fabric could occur. Extraction works perfectly on most wet-cleanable fabrics including synthetic (acrylic) velvets.

Before proceeding, test the fabric for colour-fastness. Apply a small amount of ready-to-use cleaning solution on the fabric in an inconspicuous area. Wait for 2 to 3 minutes and blot the area with a white terry cloth towel. If no colour comes off onto the towel, the fabric should be safe to clean. If a little colour comes off, there is some risk of colours running when you clean. It may be possible to stabilise colours by cleaning with B109 Fibre & Fabric Rinse.

Prepare the machine in the same manner as for carpet (see preparing the machine) cleaning except attach the upholstery tool to the vacuum hose. Connect the solution hose. Pour warm water into the solution tank. Turn on the vacuum and pump switches.

Clean with the upholstery tool using as little solution as possible by decreasing the pump pressure with regulator valve. Make overlapping passes to prevent streaking. Go over the area you just cleaned without depressing the lever (vacuum only) and gauge the amount of moisture extracted for dryness. On heavily soiled areas like arm rests, pre-treat with a recommended pre-spray.

STORAGE AND TRANSPORTATION

The machine can be prepared for storage (indoors only), by ensuring the power cord is coiled and secured using the cord storage provided.

The solution tank and waste tank are empty and clean.

The drain hose cap is fitted to the waste tank.

Transporting the machine to another site in a vehicle can be carried out if the previous conditions are met but the machine must be securely stowed.

If the machine is to be lifted into a vehicle two lifting points are supplied one being the handle recess on the front of the machine and the other the handle recess on the back of the machine.

Due to the weight of the machine it may require two people to lift it into any vehicle, or carry it upstairs.

Caution, under no circumstances should the machine be bumped up a flight of stairs using the handle, always empty the tanks before storage or transporting the machine.

USE OF PERSONAL PROTECTIVE EQUIPMENT (PPE)

Operation of this machine requires the use of protective latex gloves. Please be aware that the chemicals may require specific PPE to be worn. This can be found on the Material Safety Data Sheet (MSDS) for that particular product.

GENERAL FAULT - FINDING GUIDE

CAUTION - Repairs should only be carried out by a QUALIFIED AND FULLY TRAINED PERSON!

NO POWER

With both vacuum and pump switches in the 'on' position, the vacuum and pump will not run.

PROBABLE CAUSES CORRECTIVE ACTION

Defective power cord Replace power cord
Blown plug fuse Replace fuse
House or building circuit breaker tripped Re-set breaker switch

NO VACUUM

With the vacuum switch in the 'on' position, the vacuum will not run.

PROBABLE CAUSES CORRECTIVE ACTION

Vacuum switch defective Replace switch
Vacuum motor defective Replace
Loose wire connections Check and correct wiring

LOSS OF VACUUM

While the unit is running, there is a loss of suction at the cleaning tool.

PROBABLE CAUSES CORRECTIVE ACTION

Hole in vacuum hose Repair or replace hose
Disconnected or damaged internal hose Repair replace or reconnect hose
Waste tank lid seal defective Replace lid seal
Vacuum hose obstructed Locate and clear obstruction
Vacuum filter clogged Remove, clean and replace
Drain valve open (if fitted) Close drain valve
Vacuum motor defective Replace vacuum motor

NO PUMP PRESSURE

With the pump switch in the 'on' position, the pump will not run.

PROBABLE CAUSES CORRECTIVE ACTION

Defective pump switch Replace switch
Defective internal by-pass or check valve Inspect and replace
Defective pump motor or worn brushes Replace pump, brushes or brush end bell
Seized motor shaft or cam bearing Replace or lubricate bearing
Loose wire connections Check and correct wiring
Defective rectifier Replace rectifier

LOW PUMP PRESSURE

With the pump motor running the spray from the cleaning wand is below normal.

PROBABLE CAUSES CORRECTIVE ACTION

Solution tank filter clogged Clean as necessary
Suction leak at pump inlet Locate leak and repair
Pressure leak at pump outlet Locate leak and repair
Quick connect defective Replace quick connect
Spray tip worn, clogged or incorrectly positioned Replace, clean or re-position
Spray tip non-drip valve seized Dismantle and lubricate
Check valve assembly defective or clogged Clean or replace check valve assembly
Worn cam drive bearing (excessive noise) Replace drive bearing
Low motor speed due to partially seized bearings Lubricate or replace bearings
Clogged spray-tip filters Clean or replace spray tip filters
Pressure regulator incorrectly set or lost prime Re-set pressure regulator or re-prime

ACCESSORIES AND CHEMICALS

ACCESSORIES (OPTIONAL)

GLIDEMASTER STAINLESS STEEL CARPET WAND AC1033

Lightweight 'scrub type' stainless steel wand with insulated handle and trigger, heavy duty valve, quick connect and single spray tip.

STAINLESS STEEL UPHOLSTERY TOOL

A lightweight stainless-steel cleaning tool that, with care, will not give the problems of the softer alloy materials or plastics, the rough edges of which could damage fine fabric. Suitable for use on all wet-cleanable fine fabrics with an ultra-fine spray tip to avoid over-wetting. This tool is essential for upholstery cleaning.

CARPET & STAIR HAND TOOLS

Larger and heavier hand tool designed for extraction cleaning stair carpeting, edges, small rugs and inaccessible areas. Also ideal for rinse extracting stains after treatment with an appropriate **Prochem** spotting agent. **These tools are NOT recommended for upholstery cleaning.**

VACUUM & SOLUTION HOSES (EXTENSION)

Extension hose assemblies may be used provided they conform to the high-pressure solution hose requirements of the heater unit (if fitted) and do not exceed the maximum recommended length for the vacuum configuration. The maximum recommended length of hose for single 3-stage vacuum models is 15m (50ft) and for dual 3-stage vacuums 30m (100ft).

CAUTION- WHEN USING THE HEATER UNIT ALWAYS USE THE HIGH-PRESSURE SOLUTION HOSES SUPPLIED FOR THE CR2 MACHINE!

CHEMICALS

Prochem specialise in manufacturing chemical products for the cleaning industry, including carpets, floor coverings, upholstery fabrics and hard surfaces. This section refers only to the basic Prochem chemicals for general on-site cleaning using the hot water extraction method.

S775 EXTRACTION PLUS (CARPETS)

A general use carpet cleaning formula containing a high concentration of low foaming detergents, builders and anti-resoiling agents for effective cleaning of synthetic and natural fibre carpets. S775 has an approximate pH of 9.5 and should be diluted with hot water at 10 ml. per litre (1 to 100).

A217 ULTRAPAC RENOVATE (FLOORS AND HARD SURFACES)

New technology, solvent free restoration cleaner for the removal of ingrained soils, carbon, soot, fire residues and rubber on hard and semi-porous surfaces. Excellent cleaner for fire restoration and safety flooring. Red liquid with a floral fragrance. Dilution 1 to 50 pH10.5.

E457 NATURAL MULTI-SURFACE FLOOR CLEANER (FLOORS AND HARD SURFACES)

Powerful multi-surface neutral Ph floor cleaning concentrate, suitable for most floor surfaces including vinyl, linoleum, natural stone, marble, limestone, terrazzo, granite and ceramic tile. Biodegradable and phosphate free with eco surfactant. Clear liquid with natural lemongrass and herbal fragrance. Dilution 1 to 20 Ph 7.5.

A257 STONECLEAN (FLOORS AND HARD SURFACES)

Formulated acidic stone and tile cleaner for quarry tiles, ceramic tiles, and grout. Stoneclean will help remove soil, grease, limescale, and grout residues. Clear orange tinted liquid with mint fragrance. Dilution 1 to 50 Ph2.

S760 LIQUID DEFOAMER

Always use S760 especially when foam problems from soapy residue left from previous shampoo cleaning are encountered. Mix 20 ml. of S760 with 500ml of cold water and add to vacuum hose and recovery tank. As you drain off to empty the recovered soiled solution, you simply add more S760 as necessary. Remember always check the recovery tank for foam at the start of each job.

STAIN REMOVERS, TILE & GROUT CLEANERS & DEODORISERS

Speciality products such as those listed above are available from the Prochem range. Refer to the chemical section of the Product Catalogue for more details. Individual Product Safety Data Sheets on all products are available direct from Prochem or Authorised Prochem Distributors

PARTS DIAGRAM UPPER

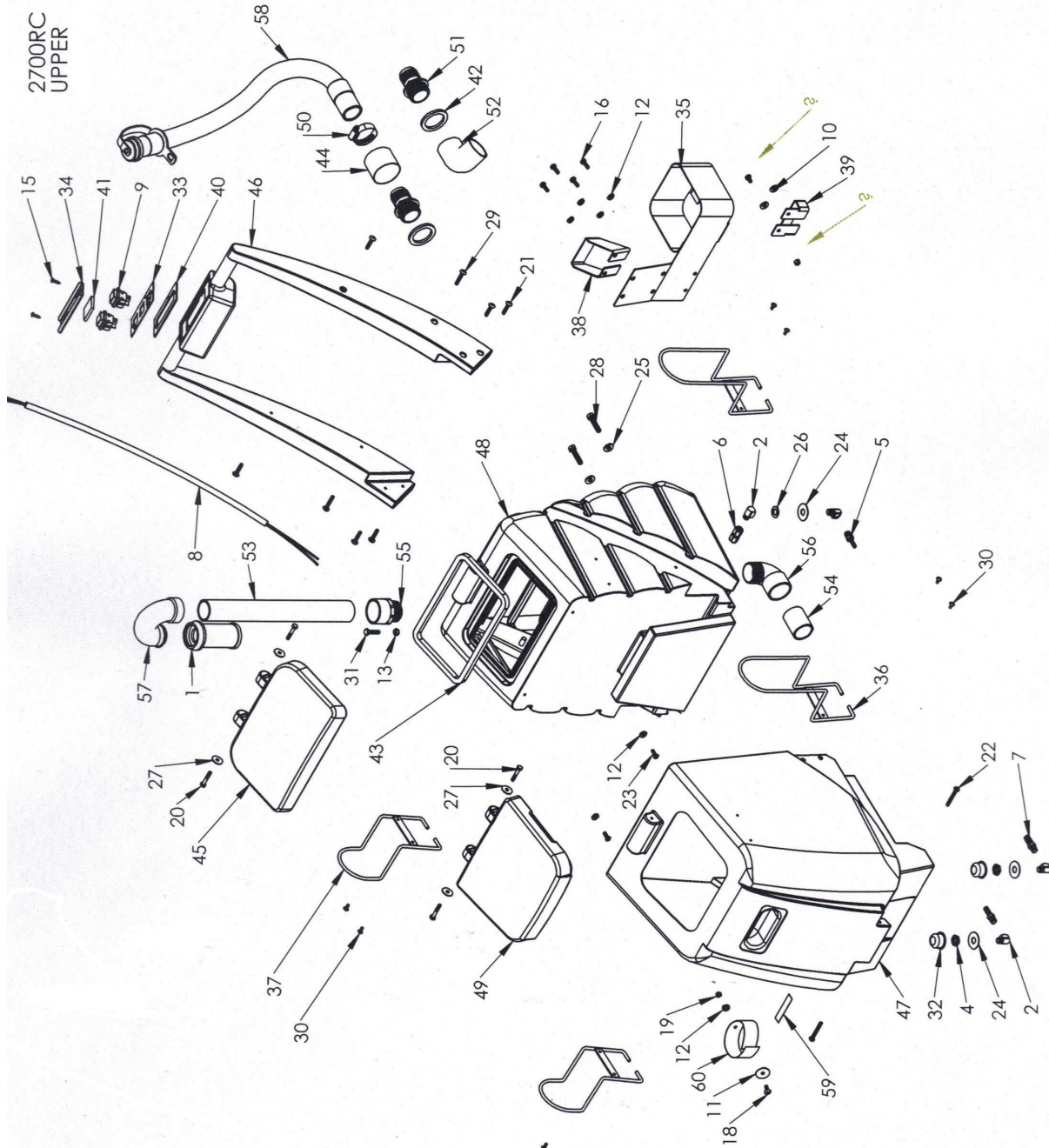

PARTS LIST UPPER

Item No	Part Number	Stock Code	Description	Qty
1	10989-2A	E10989A	BALL FLOAT	1
2	A00052	E00052	90 DEGREE ELBOW 0.25" MP X 0.25" FP	4
3	A00060		BARB, 0.375" X 0.25" MPT, BRASS	1
4	A00124	E00124	LOCKNUT, 0.25" NPT, BRASS	2
5	A00139		BARB, 0.25" X 0.25" MP, BRASS	1
6	A13881		CHECK VALVE	1
7	A90004		BARB, 0.5" X 0.25" MP, BRASS	1
8	B010314	E010314	WIRE HARNESS	1
9	B02211-1	E02211-1	ROCKER SWITCH ILLUMINATED	2
10	C00233	JE00233	FLAT WASHER, USS, SAE, 0.25" ID	2
11	C00234		WASHER, FENDER, 0.25" ID, SS	1
12	C00238		1/4" ID SEALING WASHER	7
13	C00262	JE00262	HEX NUT	1
14	C00273	JE00273	1/4-20 NYLON-INSERT LOCKNUT	2
15	C00295-1	E00295-1	#10 X 3/4" SHEET METAL SCREW, SS	2
16	C00313		1/4-20 X 0.75" HEX BOLT	4
17	C00313-1		HEX SCREW, 1/4-20 X 0.5", SS	2
18	C00316		SCREW, 1/4-20 X 3/4, PH, SS	1
19	C02251		JAM NUT, 1/4-20, SS	1
20	C02282		HEX BOLT, 1/4-20 X 1 1/2	4
21	C02294	E02294	SCREW, 1/4-20 X 1 1/4, SS	6
22	C11144		SCREW, 1/4-20 X 2" SS	2
23	C11167	E11167	1/4-20 X 3/4" SCREW, SS	2
24	C11244	JE00255	WASHER, 9/16" ID X 1.5" OD	3
25	C11540	E11540	WASHER 5/16"	2
26	C12021		WASHER, FLAT, 9/16 ID, SS	1
27	C12039	E12039	FENDER WASHER, 1/4" ID, 1" OD	4
28	C12110	E12110	HEX BOLT, 3/8-16 X 1 3/4	2
29	C13361		SCREW, 1/4-20 X 1 1/2, TRUSS, SS	2
30	C14017		SCREW, 10-32 X 1/2", TRUSS	8
31	C14067		HEX SCREW, 5/16-18 X 1 1/4", SS	1
32	D00373	EH00373	FILTER INLET	2
33	D010284	E010284	SWITCH PLATE	1
34	D03421	E03421	COVER, SWITCH PLATE	1
35	D13683		CHEMICAL BOTTLE HOLDER	1
36	D13697-2		HOSE RACK	2
37	D13698-2		RACK, SOLUTION HOSE/POWER CORD	2
38	D13711		HEATER BRACKET UPPER	1
39	D13714		HEATER BRACKET LOWER	1
40	E010453	E010453	GASKET, SWITCH BRACKET	1
41	E03433		GASKET, SWITCH BRACKET	1
42	E11128		DRAIN VALVE GASKET	2
43	E11836	E11836	GASKET RECOVERY TANK LID	1
44	E14058		SHRINK TUBING, 1/4" ID X 2.0" L	1
45	F11785-1	E11785-1	RECOVERY LID, GRANITE GREY	1
45	F11786-1	E11786-1	HANDLE, GRANITE BLUE	1
47	F11787-1-RC		SOLUTION TANK, GRANITE GREY	1
48	F11788-1		RECOVERY TANK, GRANITE GREY	1
49	F11791-1	E11791-1	SOLUTION LID, GRANITE GREY	1
50	J00650		SCREW CLAMP # 24 1.25"	1
51	K00665-1	E00665-1	1.5" HOSE ADAPTER	2
52	K00666	EN00666	1-1/2" 90 DEGREE ELBOW	1
53	K00672		PVC PIPE, 1.5" SCH40, 1.3125'	1
54	K00672-1	E00672-1	PVC PIPE, 1.5" X 2.25", SCH40	1

55	K00741	E00913-P	ADAPTER MALE, 1.5",SCH40	1
56	K11185	E11185	90 DEGREE ELBOW, SCH40, MPT SF	1
57	K11965		RETURN BEND, 1.5"	1
58	K13724		DRAIN HOSE ASSEMBLY	1
59	S11179		NON-SKID TAPE	1
60	S13706-A		STRAP WAND VELCRO	1

PARTS DIAGRAM BASE

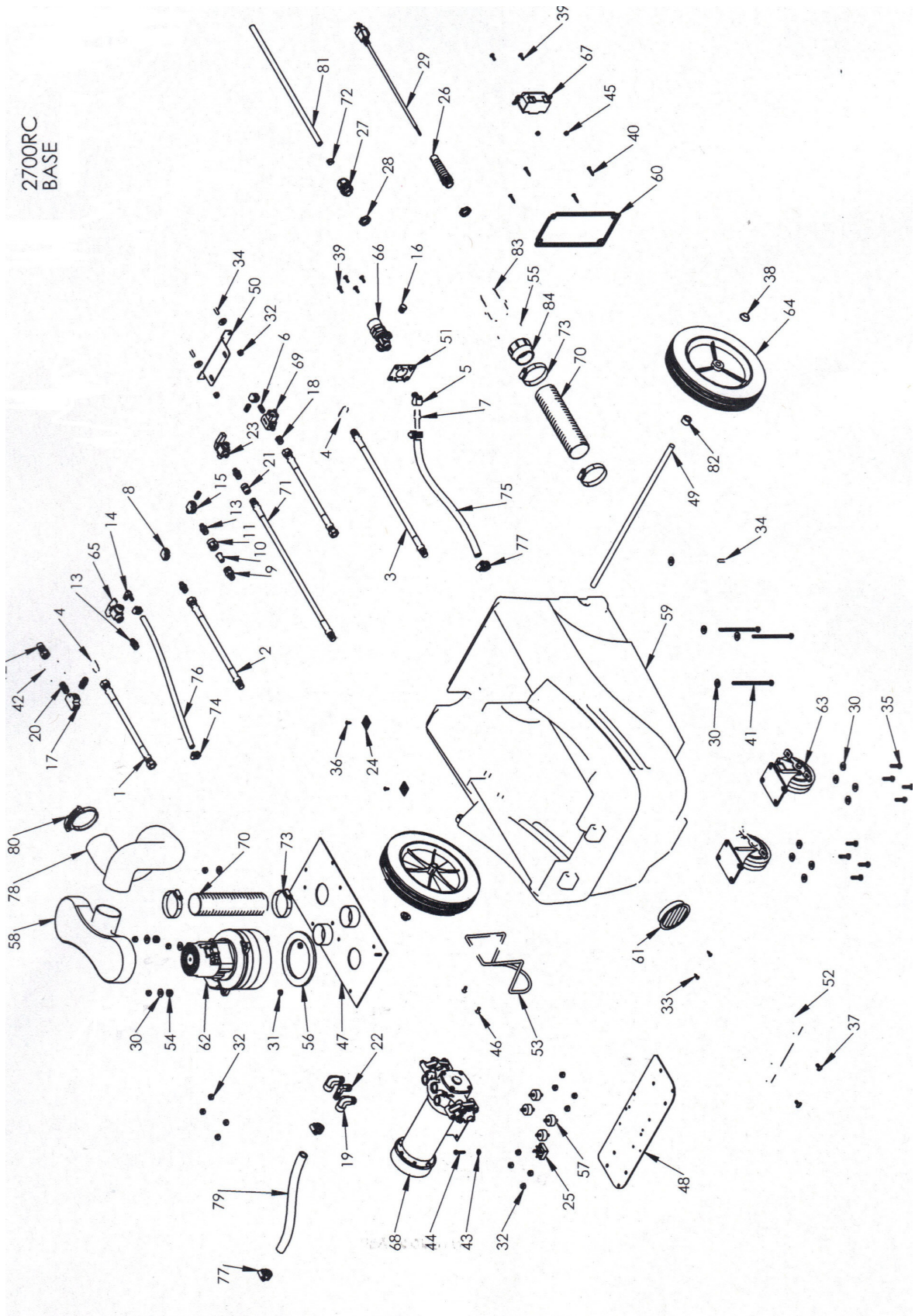

PARTS LIST BASE

Item No	Part Number	Stock Code	Description	Qty
1	-			
2	-			
3	-			
4	A00052	E00052	90 DEGREE ELBOW, 0.25" MP X 0.25" FP.	2
5	A00053	E00053	45 DEGREE ELBOW, 0.25" MP X 0.25" FP.	1
6	A00055	E00055	NIPPLE, 0.125", CLOSE, BRASS.	3
7	A00060		BARB, 0.375" X 0.25 MPT, BRASS.	1
8	A00073	E00073	90 DEGREE ELBOW, BRASS.	2
9	A00094C	DE4906	BODY, CHECK VALVE, 0.25" M.	1
10	A00094E	E00094E	CHECK VALVE.	1
11	A00097A	E00097-A	CAP, IN LINE FILTER.	1
12	A00102	GU00102	QD, 0.25" M X 0.25" FP, BRASS.	1
13	A00114B		HEX NIPPLE, 0.25" MP X 0.125" MP.	4
14	A00134		90 DEGREE ELBOW, 0.25" BARB X 0.125" MPT	1
15	A00135	E00135	TEE, 0.125" FP X 0.125" MP.	1
16	A00155		PLUG, MALE, 0.25".	1
17	A00161	E00161	TEE, 0.25" FP X 0.25FP X 0.25" FP	1
18	A00168-18	E00095-1	BUSHING, 0.25" M X 0.125" F.	1
19	A12917		ELBOW, 0.25" F X 0.375" M, NPT.	2
20	A12960	CH00111	NIPPLE, HEX, 0.25" X 0.25", BRASS.	2
21	A12964	E12964	COUPLER, .25", BRASS.	1
22	A13430		BARB, ELBOW, 0.375" MP X 0.5" BARB.	1
23	A13688		BALL VALVE, 3- WAY, 0.125".	1
24	B00192		TIE HOLDER, WITH ADHESIVE.	2
25	B02229	E02229	BRIDGE RECTIFIER, 25A.	1
26	B11606		STRAIN RELIEF, PIGTAIL.	1
27	B11821		STRAIN RELIEF.	1
28	B11832		STRAIN RELIEF NUT.	1
29	B13695	BE4901	POWER CORD, 13A, 25FT, 1.5MM.	1
30	C00233	JE00233	FLAT WASHER, USS, SAE, 0.25" ID.	18
31	C00261	JE00261	HEX NUT, 1/4-20.	3
32	C00273	JE00273	1/4-20 NYLON INSERT LOCKNUT.	22
33	C00293	E00293	#8-32 X 0.5" PAN HEAD SCREW.	2
34	C00313		1/4-20 X 0.75" HEX BOLT	3
35	C00314-1	E00314-1	HEX BOLT 1/4-20 X 1".	8
36	C02237		SCREW, #8 X 0.5" SMS, FH.	2
37	C02242		SCREW, 1/4-20 X 0.5", TRUSS.	2
38	C02305	E02305	CAP NUT, 1/2" PUSH ON.	2
39	C10737	E10737	#8-32 X 0.625" TRUSS HEAD SCREW, SS.	6
40	C11165	E11165	SCREW, #8 x 1", PH, SMS.	4
41	C11189	E11189	HEX BOLT, 1/4-20 X 4.5".	3
42	C11244	JE00255	WASHER, 9/16" ID X 1.5" OD.	2
43	C11955		WASHER, #10.	1
44	C13026		SCREW, 10-32 X 1" HEX.	1
45	C13120		#8-32 HEX NUT W/ LOCK WASHER.	2
45	C14017		SCREW, 10-32 X 1/2", TRUSS.	2
47	D11134-1		PLATE VACUUM BASE.	1
48	D11835	E11835	PLATE, PUMP	1
49	D13188		SHAFT, WHEEL, 18" X 0.625".	1
50	D13347		BRACKET.	1
51	D13620		PLATE, REGULATOR.	1
52	D13684		BRACKET, WAND.	1
53	D13698-2		RACK SOLUTION HOSE/POWER CORD.	1
54	E00449	E00449	GROMMET.	3
55	E11128		DRAIN VALVE GASKET.	1
56	E11169	E11169	GASKET, VACUUM MOTOR	1

57	E13867		SANDWICH MOUNT, NEOPRENE.	4
58	F11178-1		INTERCOOLER, SINGLE PORT.	1
59	F11789-1-RC		CR2 BASE, GRANITE BLUE.	1
60	F11790-1		HEATER PORT, COVER PLATE.	1
61	F13820		LOUVRE, 3", BLACK.	1
62	G02517-1	LA4501E	MOTOR, VACUUM 5.7", 3 – STAGE.	1
63	G03518-L	E03518	CASTOR, LOCKING, 4".	2
64	G11767	E010313	WHEEL, 10" X 1.75".	2
65	G13380		VALVE, PRESSURE RELIEF.	1
66	G13634		REGULATOR, 300-500PSI.	1
67	G13869		PUMP 500PSI	1
68	G14021		CHEMICAL INJECTOR	1
69	J00618	E00618	2" ID HOSE.	2
70	J00632-1		PULSE HOSE, 32".	1
71	J00635		CLAMP, TUBE, 0.5" ID.	1
72	J00639		2" ID HOSE CLAMP.	4
73	J00651		HOSE CLAMP, 0.25" TO 0.625".	2
74	J11154	E11154	SOLUTION HOSE, 100PSI, WIRE, 0.375"ID X 5' L.	1
75	J11154-1		SOLUTION HOSE, 0.25" ID X 4.9'.	1
76	J11508		SCREW CLAMP, #6.	4
77	J11863	E11863	HOSE, INTERCOOLER.	1
78	J11933		HOSE, POLYWIRE, PVC,0.5" ID.	1
79	J13152		CLAMP, HOSE, DOUBLE GRIP.	1
80	J14016		TUBING, CLEAR, 0.25"ID, 0.5" OD, 5FT.	1
81	K00662-50		SPACER, 0.5" X 0.5"	2
82	K00665-1	E00665-1	1.5" HOSE ADAPTER.	1
83	K13843		ADAPTER, 1.5" PVC, SCH40.	1

WIRING DIAGRAM

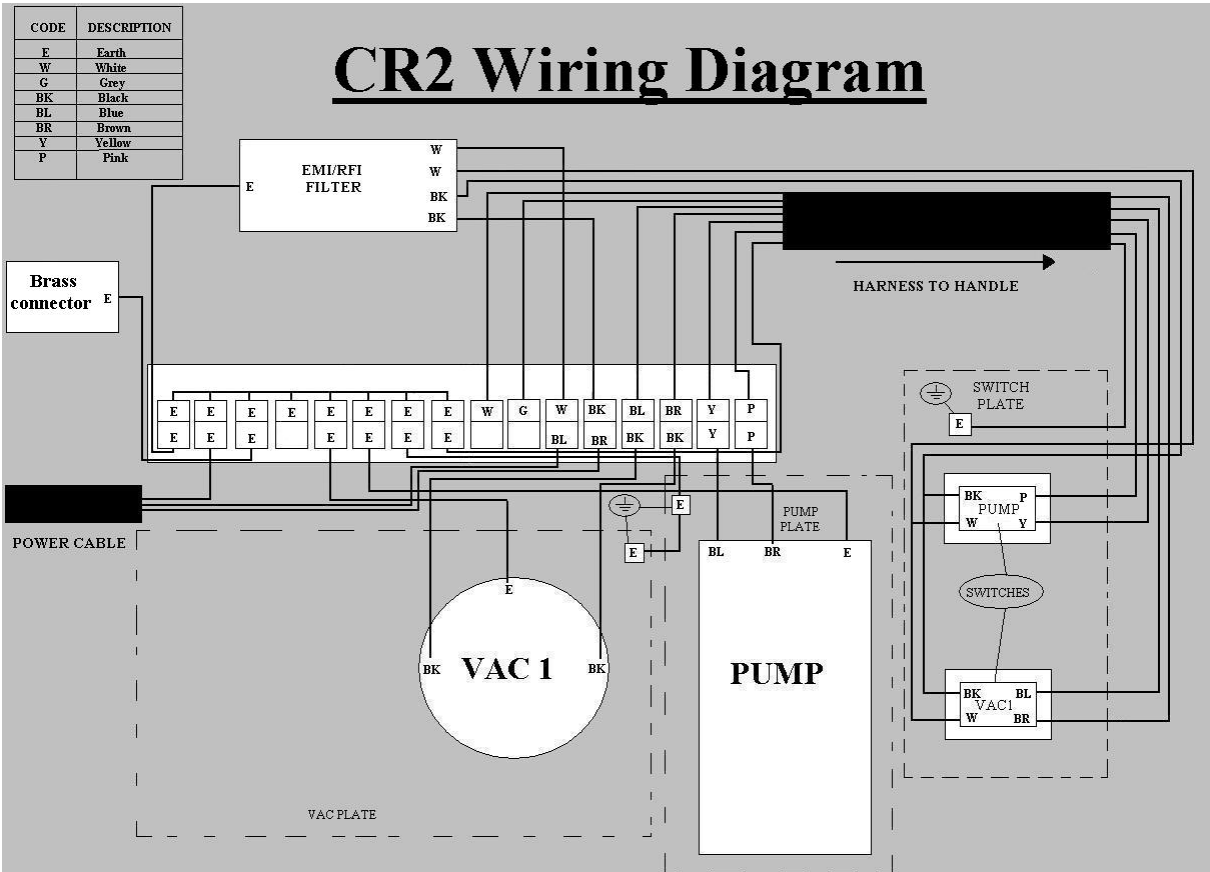

DECLARATION OF CONFORMITY

We:
Prochem Europe Ltd.,
Oakcroft Road,
Chessington,
Surrey, KT9 1RH
UK
(Importer / EC Responsible Person)

E.D.I.C
1753, Blake Avenue,
Los Angeles,
California, 90031-1006
USA
(Manufacturer)

Declare that the product(s):

Type(s): **CR2**
Model(s): **RC2700**
Description: **MULTI-SURFACE CLEANING MACHINE 220-240V 50HZ**

Have been manufactured in conformity with the following standards and specifications:

BS EN 60335-1
BS EN 60335-2-68
EN 55014-1
EN 55014-2
BS EN 61000-3-2
BS EN 61000-3-3
BS EN 50366

And comply with the requirements of (as amended):

2014/35/EU	Low Voltage (LVD) Directive
2004/108/EC	Electromagnetic Compatibility (EMC) Directive
2015/863/EU	RoHS Directive

A Technical file is held by Prochem Europe Ltd.

Certificate of compliance and test reports have been issued by:

Signed
(For and on behalf of the Importer / EC Responsible Person)



Name: J Hattersley
Position: Equipment Product Manager
Place of Issue: Chessington UK
Date of Issue: 29/3/21